

BG - Осветителното тяло трябва да бъде монтирано и въведено в експлоатация единствено от специалист с подходящо електротехническо образование. Преди свързването му към захранващата клемна първо се уверете, че няма наранена или липсваща изолация по захранващите проводници. Цветният код на кабелите е черен или кафяв (L) - фазов проводник, син N нулев проводник и жълто-зелен - защитен (зануляващ) проводник - при тела защитени срещу поражение от електрически ток клас 1. Видът на източника на напрежение, както и останалите технически характеристики са посочени в таблица. **EN** - The light fitting must only be mounted and put into operation by a qualified electrician! Make sure that you do not damage any electric cables when you are mounting the light fitting. The colour codes of the wire are the following: black or brown (L) = phase conductor, blue (N) = neutral conductor, and in the case of a light fitting of shock protection class 1: green-yellow =protecting conductor. Only a light source of maximum performance and of the type indicated in the data plate and around the socket can be used for the product. The light fitting must only be mounted and put into operation by a qualified electrician! **D** - Die Montage und Inbetriebsetzung des Leuchtkörpers darf nur von Fachleuten vorgenommen werden! Bei der Montage des Lichtkörpers soll darauf geachtet werden, dass das elektrische Kabel nicht verletzt wird. Die Leitungen sind mit den folgenden Farben versehen: schwarz oder braun (L)=Phasenleiter, blau (N) = Nullleiter, und bei Leuchtkörpern mit Berührungsschutz klasse 1. : grün - gelb = Schutzleiter.

CZ - Montáž a zprovoznění lampy smí provádět výhradně jenom odborná osoba. Při montáži lampy dejte pozor na to, aby jste náhodou nepoškodil elektrický kabel. Význam používaných barev u kabelů jsou následující: černá, nebo hnědá (L) = fázový vodič, modrá (N) = nulový vodič, u lampy s proti dotykovou ochranou: zele- ná-žlutá = ochranný (uzemnění) vodič. **SLO** - Namontovanje osvetlovalnega telesa a jeho uvedenie do prevádzky môže vykonávať len odborník! Pri namontovaní osvetlovalného telesa dbajte na to, aby ste neporušili kábel elek-trického vedenia. Farebné označenia vodičov sú nasledovné: čierna, alebo hnedá farba (L) = fazový vodič, modrá (N) = nulový vodič, a v prípade osvetlovalného telesa patriaceho do I. triedy ochrany pred nebez-pečným dotykom: zelená-žltá = ochranný vodič. **PL** - Lampa może być zamontowana i uruchomiona tylko przez specjalistę! Przy montowaniu lampy należy uważać, aby nie uszkodzić kabla elektrycznego. Oznakowanie kolorów kabli: czarny lub brązowy (L) = przewód fazowy, niebieski (N) = przewód zerowy i w przypadku lampy I. ochrony kontaktu: zielono-żółty =przewód ochronny. **HU** - A lámpatest felszerelését és üzembe helyezését csak szakember végezheti! A lámpatest felszerelésénél vigyázzon arra, hogy ne sértsen meg elektromos ká-belt. A vezetékek színjelölései a következők: fekete vagy barna (L) = fázisvezető, kék (N) = nulla vezető, és 1. érintésvédelmi lámpatest esetén: zöld-sárga védővezető. **SK** - Montiranje in stavljenje svetilke v obrat sme izvrševati le strokovnjak! Pri montiranju svetilke pazite da ne poškodujete električnega kabla. Barvna zaznamovanja vod so naslednja: črna ali rjava (L) = fazni vod, modra (N) = neutralni vod, in v primeru svetilke z zaščito pred dotikom: zelena- rumena = zaščitni vod. **BiH** - Montažu rasvjetnog tijela i stavljanje u pogon može izvršiti samo stručna osoba! Kod montaže rasvjetnog tijela pazite da ne oštete električni kabel. Označavanje kablova prema bojama: crna ili smeđa (L)= faza, plava (N) = nula, i kod rasvjetnog tijela sa 1. stupnjem zaštite zeleno-žuta = uzemljenje. **SRB** - Montažu lampe i stavljanje u pogon može izvršiti samo stručna osoba. Pri liokm montaže lampe pazite da ne oštete kabel. Značenje kablova prema bojama: crna ili smeđa (L)= faza, plava (N) = nula, i kod lampi sa 1 stepenom zaštite zeleno-žuta = uzemljenje. **RO** - Montarea și punerea în funcțiune a corpului de iluminat poate fi realizată doar de personal de specialitate! La montarea corpului de iluminat urmăriți să nu deteriorați cablurile electrice. Marcarea cu colori a cablurilor este următoarea: negru sau maro (L) = cablu de fază, albastru (N) = cablul nul, și în cazul corpului de iluminat cu clasa de împământare I.: verde-galben = împământare. **GR** - Η τοποθέτηση και οι ρυθμίσεις πρέπει να γίνονται μόνο από ειδικό. Στην τοποθέτηση πρέπει να προσέξετε να μην προκαλέσετε φθορές στο καλώδιο. Το χρώμα των καλωδίων είναι οι εξής: μαύρο ή καφέ (L) = φάση, μπλε (N) = ουδέτερο, και σε περίπτωση φωτιστικών με προστασία ηλεκτροπληξίας κλάσης 1: κίτρινο-πράσινο = καλώδιο προστασίας; **IT** - Per la tua sicurezza, l'installazione e la messa a punto vengono eseguite solo da uno specialista!; **HR** - Za vašu sigurnost, instalacije i ugađanje izvodi samo stručna osoba!; **MK** - Za vašu bezbednost, instalacija i podesuвање се изведува само од специјалист!; **PL** - Ze względów bezpieczeństwa instalację i strojenie wykonuje tylko specjalista!; **P** - Para sua segurança, a instalação e o ajuste são realizados apenas por um especialista!

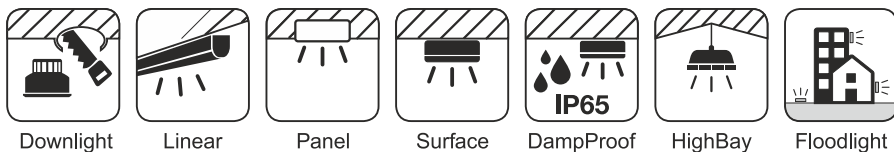

RoHS



2+0
standard
+extended
2 YEAR TOTAL
WARRANTY

- (BG) Инструкция за монтаж и експлоатация
- (EN) Instruction for installation and use
- (RO) Instrucțiune de instalare și utilizare
- (SRB) Uputstvo za ugradnju i upotrebu
- (HR) Uputstvo za ugradnju i upotrebu
- (BIH) Uputstvo za ugradnju i upotrebu
- (HU) Szerelési és kezelési utasítás
- (SLO) Navodilo za vgradnjo in uporabo
- (GR) Οδηγιοσ για την εγκατασταςη και τη χρηση
- (MK) Упатство за вградување и употреба
- (SK) Návod na montáž a používanie
- (PL) Instrukcja instalacji i użytkowania
- (P) Instrução para instalação e uso
- (IT) Istruzioni per l'installazione e l'uso



- (BG) LED Осветител
- (EN) LED fixtures
- (RO) Lampa mobilier cu LED
- (SRB) LED Svetiljka
- (HR) LED svjetiljke
- (BIH) LED Svjetiljka
- (HU) LED pultmegvilágító
- (SLO) LED svetila
- (GR) Φωτιστικό LED Επίπλων
- (MK) LED Светилки
- (SK) LED svietidlá
- (PL) Oprawy LED
- (P) Luminárias LED
- (IT) Infissi a LED

ELMARK
The Brand of Electricity
www.elmarkholding.eu

Read carefully before installation



www.elmarkholding.eu

STREAM STELLAR

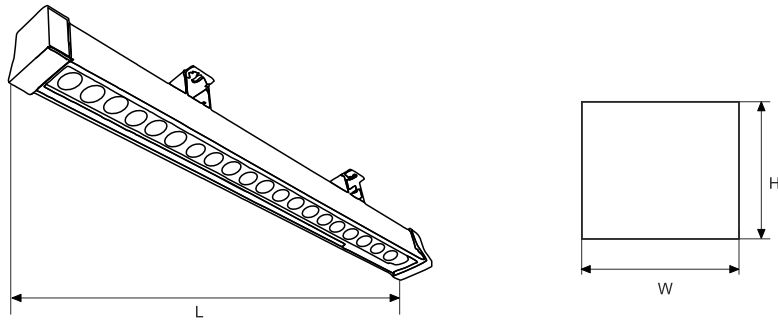

Catalogue number	Watt (W)	Whole fixture lumens (lm)	Colour temp. (K)	Beam angle	Colour body	Length (mm)	Width (mm)	Height (mm)
98STREAM9	9	720	5500	90°	grey	300	50	56
98STREAM18	18	1440	5500	90°	grey	600	50	56
98STREAM36	36	2880	5500	90°	grey	1000	50	56
98STREAM9RGB	9	-	RGB	90°	grey	300	50	56
98STREAM18RGB	18	-	RGB	90°	grey	500	55	60
98STREAM36RGB	36	-	RGB	90°	grey	1000	50	56

Body: aluminium casting | LED driver: mounted in the body | Light source: Epistar | Ambient Temperature: -25°C ÷ +55°C



Precautions for installation of LED wall washing lamp

1. Please turn off the power before installation to avoid electric shock due to improper operation.
2. Pay attention to check whether the voltage marked on the wall washing lamp is consistent with the input voltage to be connected. If it is different, it is best not to connect to avoid led damage.
3. If it is not used normally, its service life will be reduced. Do not use it in places with thick acid mist.
4. Pay attention to shockproof during installation and transportation, otherwise it is easy to be damaged.
5. Before installation, ensure the installation position. After installation, there is a lot of swing. If there is, it can be checked.
6. If the lamp fails, please place the lamp in one place and send it back to our company for inspection and maintenance.
7. If the lamp body wire is found to be damaged, please cut off the power immediately and stop using it.

